





S2- Nastratrice semiautomatica - Semi-automatic carton sealer - Machine d'emballage semi-automatique - Halbautomatische verschliessmaschine - Precintadora semiautomática

 **S2** - Nastratrice semiautomatica a dimensionamento manuale. Facile da usare e semplice nelle regolazioni, consente ad ogni operatore di avviarla alla produzione in pochi minuti. Con il doppio sistema di trascinamento superiore/inferiore e la collaudatissima unità nastrante K11, assicura una perfetta chiusura della scatola con nastro adesivo. La macchina è stata progettata e costruita con riferimento alla **Direttiva Macchine CE 392 e Successivi Aggiornamenti**.

 **S2** - Semi-automatic carton sealer with manual adjustment. Easy to be used and simple to be adjusted, it can be started by any operator in few minutes. It allows a perfect closing of the box by adhesive tape thanks to the double top and bottom driving system and the super reliable taping unit K11. The carton sealer has been designed and built according to the **CE 392 Machine Directives and subsequent revisions**.

 **S2** - Machine semi-automatique à réglage manuel. Facile à employer et simple dans les réglages, elle donne la possibilité à tout opérateur de la faire marcher dans quelques minutes. Avec le double système d'entraînement supérieur/inferieur et la très essayée unité d'enrubannage K11, elle est en mesure d'assurer une fermeture parfaite de la boîte parmi le ruban adhésif. La machine a été projetée et construite selon la **Directive Européenne sur les machines CE 392 ainsi que ses mises à jour successives**.

 **S2** - Halbautomatische Verschliessmaschine mit manueller Bemassung. Einfache Verbrauch und einfach zu verstellen, erlaubt die Maschine jedem Bediener sie ganz schnell zum Arbeit zu vorbereiten. Durch das doppelte obige und untere Förderungssystem und durch die hochgetesteten Verschliesseinheiten K11, versichert die Maschine einen einwandfreien Verschluss der Schachtel mittels Klebeband. **Die Maschine ist mit Bezeichnung an den EEC Richtlinien 392 und nach den neuesten Ergänzungen entworfen und gebaut worden.**

 **S2-** Precintadora semiautomática a dimensionamiento manual. Fácil de usar y de sencilla regulación, permite que el operador, la ponga en funcionamiento en pocos minutos. Con el doble sistema de arrastre superior/inferior y la más que probada unidad precintadora K11, asegura un cierre perfecto de la caja con cinta adhesiva. La máquina ha sido proyectada y construida con referencia a la **Diretiva Máquinas CE 392 y versione sucesivas**.

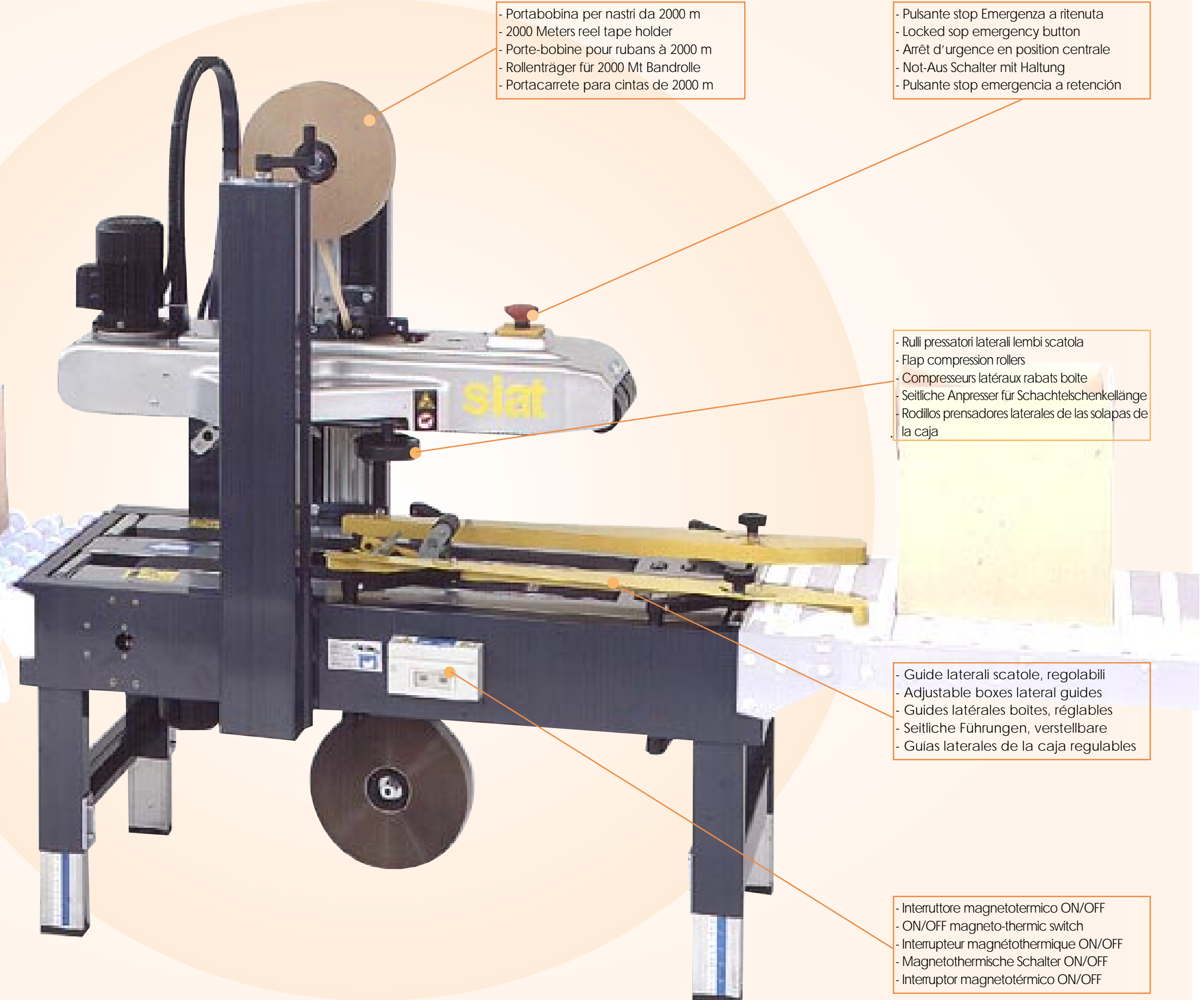

- Portabobina per nastri da 2000 m
- 2000 Meters reel tape holder
- Porte-bobine pour rubans à 2000 m
- Rollenträger für 2000 Mt Bandrolle
- Portacarrete para cintas de 2000 m

- Pulsante stop Emergenza a ritenuta
- Locked stop emergency button
- Arrêt d'urgence en position centrale
- Not-Aus Schalter mit Haltung
- Pulsante stop emergencia a retención

- Rulli pressatori laterali lembi scatola
- Flap compression rollers
- Compresseurs latéraux rabats boîte
- Seitliche Anpresser für Schachtelschenkellänge
- Rodillos prensadores laterales de las solapas de la caja

- Guide laterali scatole, regolabili
- Adjustable boxes lateral guides
- Guides latérales boîtes, réglables
- Seitliche Führungen, verstellbare
- Guías laterales de la caja regulables

- Interruttore magnetotermico ON/OFF
- ON/OFF magneto-thermic switch
- Interrupteur magnétothermique ON/OFF
- Magnetothermische Schalter ON/OFF
- Interruptor magnetotérmico ON/OFF

S2

- ◆ Caratteristiche tecniche
- ◆ Technical specifications
- ◆ Caractéristiques
- ◆ Eigenschaften
- ◆ Características técnicas

- ◆ Accessori
- ◆ Optionals
- ◆ Accessoires
- ◆ Zubehör
- ◆ Accesorios

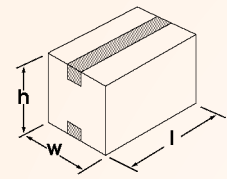

	MIN	MAX
l	150	∞
w	140	500
h	110	500

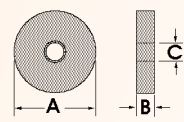

A	= 410 mm max.
B	= 50 mm
C	= 76 mm

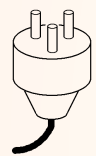

380÷440 • Trifase • 3 Phase • Tri-phasé
• 3-phasisig • Trifasico

220÷240 • Monofase • Single phase
• Mono-phasé • 1 phasig
• Monofasico

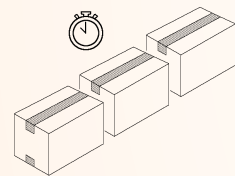

Produzione media: 800 scatole/ora
Output: 800 boxes per hour
Production moyenne: 800 boites/heure
Leistung: 800 Schachtel/Stunde
Producción media: 800 cajas/hora

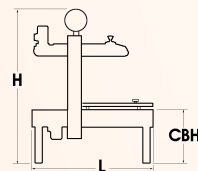

H	= 1238÷1955 mm
CBH	= 480÷820 mm
L	= 1240 mm
W	= 740 mm

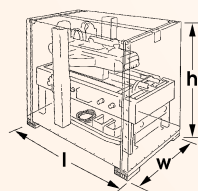

h	= 1100 mm
w	= 80 mm
l	= 130 mm

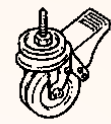

AS77

- ◆ Set ruote Ø100 mm
- ◆ Casters
- ◆ Roues
- ◆ Satz Umlaufräder
- ◆ Set ruedas



AS80

- ◆ Set gambe più alte (600 mm)
- ◆ Higher legs (600 mm/24")
- ◆ Pieds plus hauts (600 mm)
- ◆ Höhere Stützen (600 mm)
- ◆ Set patas mas altas (600 mm)

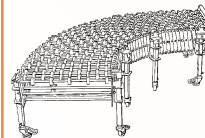

GTM-GTL-GTR

- ◆ Piani estensibili
- ◆ Extendable conveyors
- ◆ Convoyeurs extensibles
- ◆ Ausziehbare Rollenbahnen
- ◆ Plano de rodillos extensibles

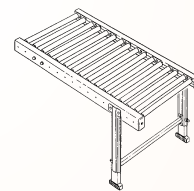

RN/RG

- ◆ Piani a rulli
- ◆ Idler roller conveyors
- ◆ Plans à rouleaux
- ◆ Rollenbahnen
- ◆ Tramo de rodillos

MARCATORE A GETTO D'INCHIOSTRO - INK-JET MARKER - MARQUEURS A
JET D'ENCRE - TINTENSTRAHLMARKIERER - MARCADOR INK-JET



siat®

the new generation

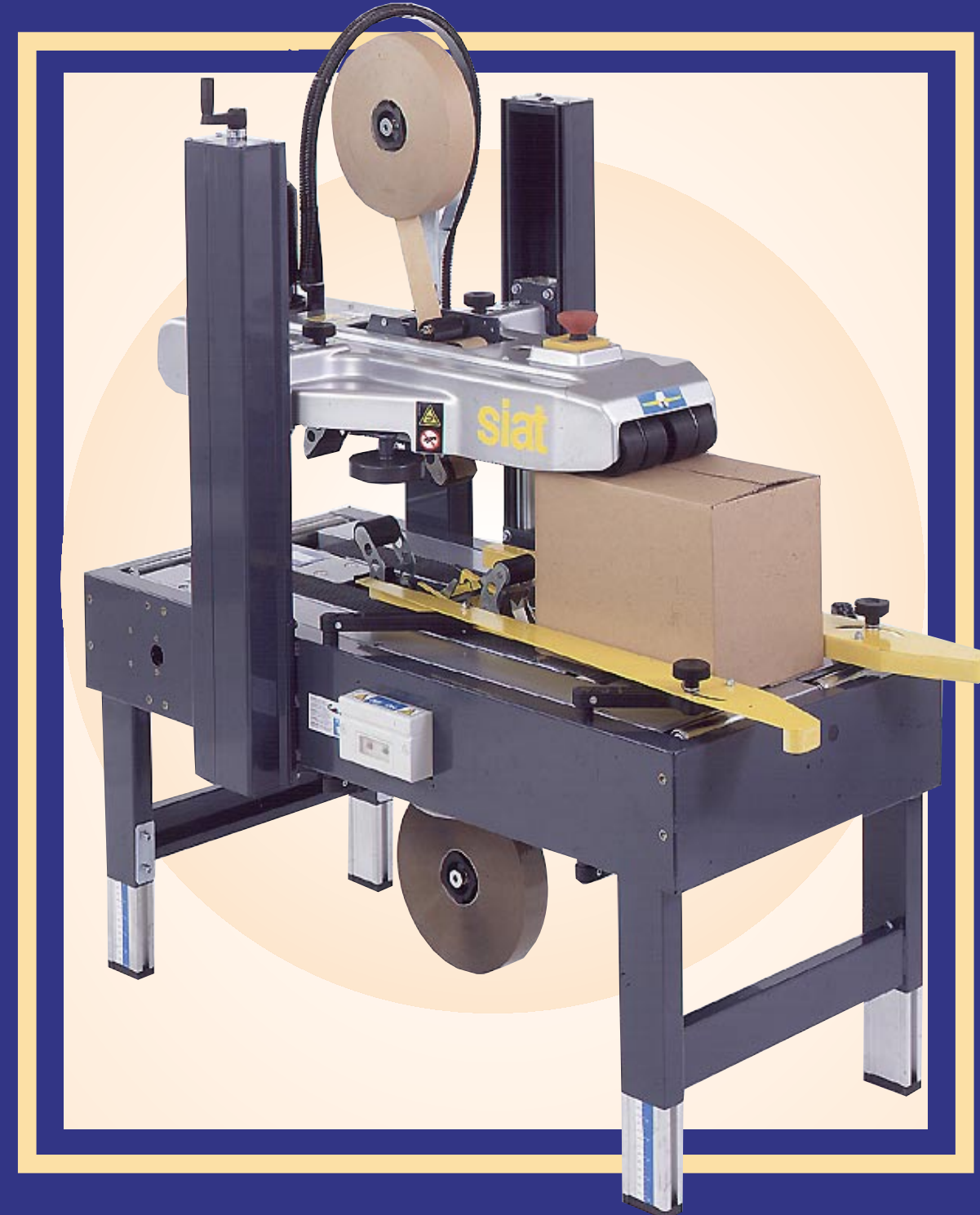

S2

Nastratrice semiautomatica
Semi-automatic carton sealer
Machine d'emballage semi-automatique
Halbautomatische Verschlussmaschine
Precintadora semiautomática

