

# AS2 PLUS NT



# AS2 PLUS NT

Automatic labeling machine with  
print and apply from below

## Main features

- Cadences up to 150 ppm.
- 2 motorized belts, closed loop.
- Brushless motors and drive boards, speed up to 70 m/min.
- Working temperature: from 0 °C to + 40 °C.
- Power supply: 230 Vac (Hz 50/60).
- Maximum power: 1,15 kW.
- Resistive PC/Panel 12" display, suitable for use with gloves and in the presence of water/condensation.
- Structure and carpentry in aluminum and stainless steel.
- Belt height from the ground: 850 +/- 50 mm.
- Machine management by PLC.
- Print mode: thermal transfer and/or direct.
- Resolution: 8 dots/mm, 203 dpi (optional: 12 dots/mm, 300 dpi).
- Print speed: 203 dpi, 457 mm/s - 300 dpi, 300 mm/s.
- Label dimensions: from 40x40 to 110 mm x 110 mm.
- Print width: 104 mm.
- Internal diameter of the roll: 76 mm.
- Outer diameter of the roll: 300 mm.
- 600 meter ribbon capacity.
- Label application with electronic motorized belt.
- Linear movement on bearings for positioning the printing unit.

## Software

- Machine management program.
- Program for printing and editing labels with image technology. Sw custom label.

### Selectable functions

- External availability for data sharing.
- Multilingual selection.
- Multi-level password.
- Remote support.

### PLU

- PLU number: 9999.
- All fields can be printed in bold, italic, underlined, single character, supporting different types (fonts, alignments, sizes, bold etc.) of character in the same text.
- Automatic programming of machine parameters (motor speed, label and variable application along the X axis).

### Label formats

- Customizable label formats (editable print format on the machine).
- Rotation of the label format: 0, 90, 180, 270.
- Rotation of the fields.
- Print in bold, italic, underlined, single font.
- It supports different fonts, not just per line.
- It supports and prints logos.
- Support of all barcodes.

### I/O Section

- 1 USB 2.0.
- 1 Ethernet.
- 2 electrical signals (clean contacts).

### Diagnostics

- Continuous monitoring of the status of the machine and of all integrated systems (consent from downstream, motor failure, encumbrances on the belts and all errors resulting from the printing system such as paper end, end ribbon, paper passage and wear of the print head).

- Print resolution: 300 dpi, speed 300 mm/s.
- 2D camera for label presence.
- 2D camera for reading QR Code.
- External PROFIBUS interface, Profibus protocol with PCB.
- Communication protocol ETHERCAT.
- Pair of stainless steel product guides.
- Side printing unit positioning kit.
- Swivel wheels kit with brake.

**Series 230 useful belt dimensions [mm]**

INPUT BELT	OUTPUT BELT
230x750	230x510 only printer from below.
230x1200	230x510 configurable with printer above (optional).
230x1600	230x510 configurable with printer above (optional).

**Series 275 useful belt dimensions [mm]**

INPUT BELT	OUTPUT BELT
275x750	275x510 only printer from below.
275x1200	275x510 configurable with printer above (optional).
275x1600	275x510 configurable with printer above (optional).

**Series 320 useful belt dimensions [mm]**

INPUT BELT	OUTPUT BELT
320x750	320x510 only printer from below.
320x1200	320x510 configurable with printer above (optional).
320x1600	320x510 configurable with printer above (optional).

**Series 420 useful belt dimensions [mm]**

INPUT BELT	OUTPUT BELT
420x750	420x510 only printer from below.
420x1200	420x510 configurable with printer above (optional).
420x1600	420x510 configurable with printer above (optional).

**Series 510 useful belt dimensions [mm]**

INPUT BELT	OUTPUT BELT
510x750	510x510 only printer from below.
510x1200	510x510 configurable with printer above (optional).
510x1600	510x510 configurable with printer above (optional).

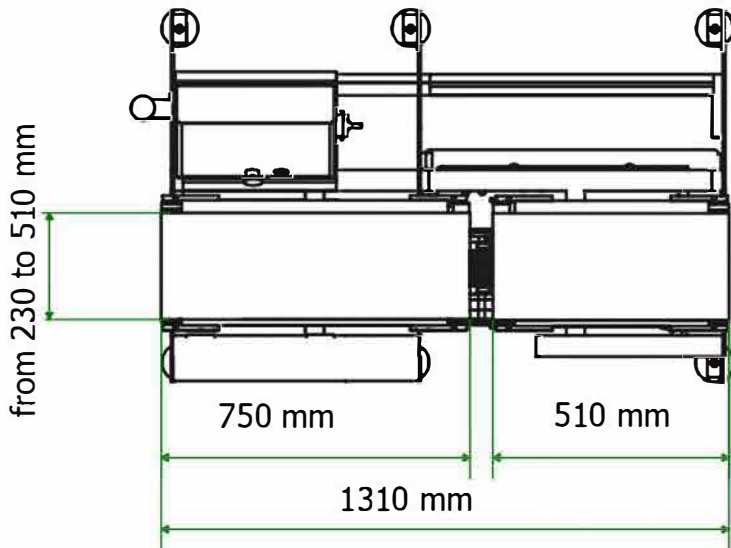
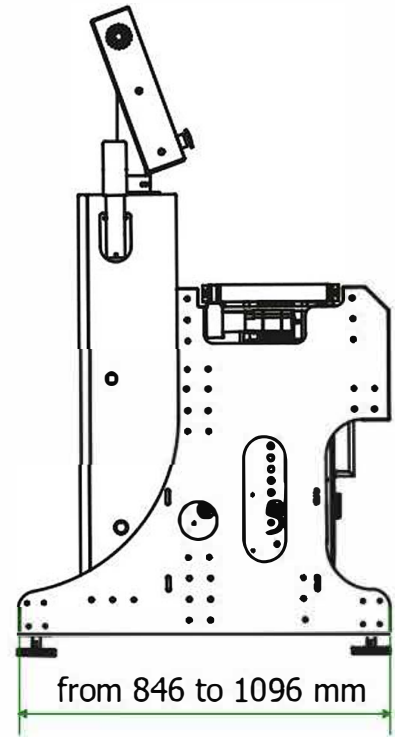
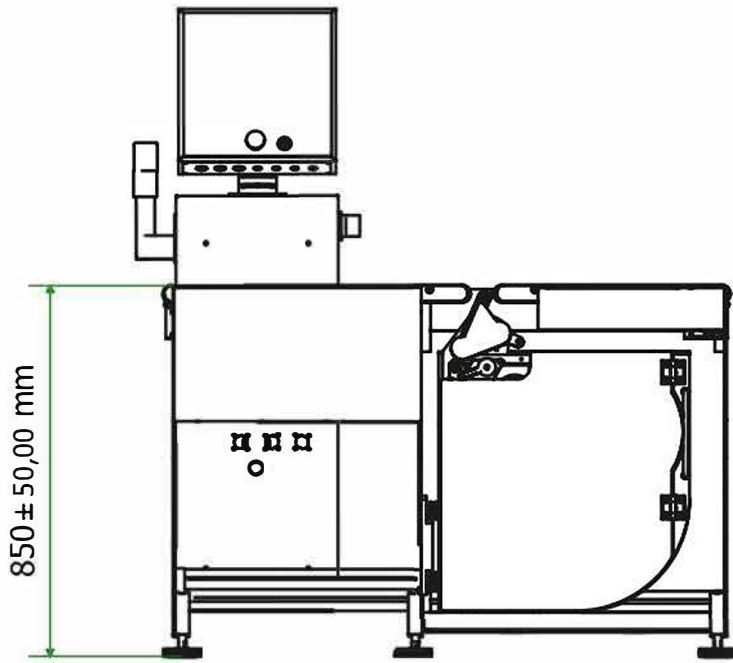

# Layout

Configurable with printer above (optional)

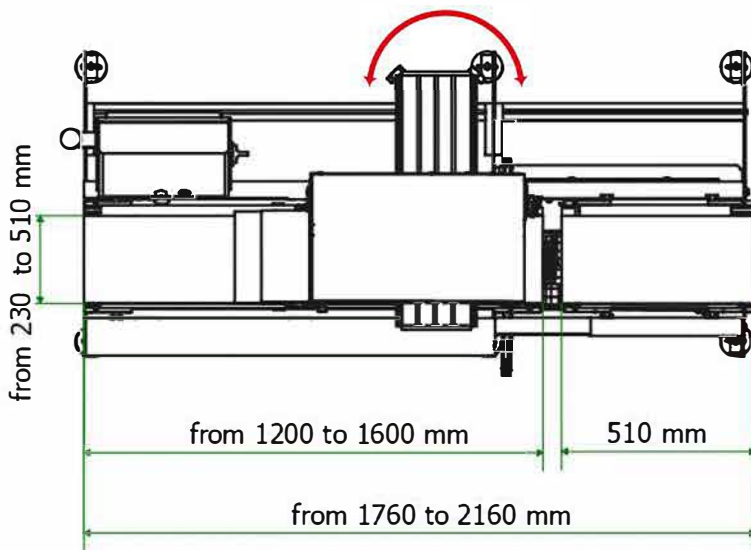
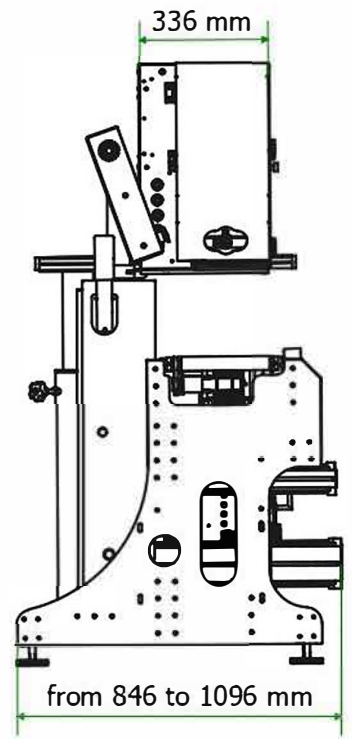
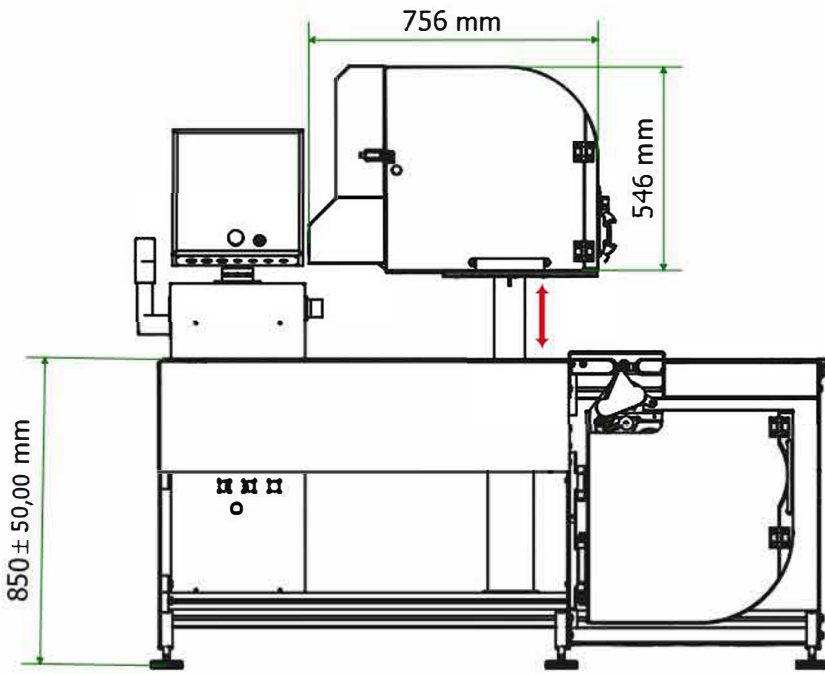

Technical specifications and images may be subject to improvements and modifications without notice.

# AS2 PLUS NT

**MID APPROVAL**

**MODULAR AND INTEGRABLE**

**REDUCED MAINTENANCE COSTS**

**SELF-DIAGNOSTIC**

**CONNECTIVITY AND DATA SHARING WITH OTHER SOFTWARE**

**REMOTE ASSISTANCE**

**DISTRIBUIDO POR:**



PACKLINE SPAIN SYSTEM, S.L.  
Actor Mora, 22-46009 Valencia  
Tel. •34 610277275  
pcano@packspainsl.com - WWW.packspainsl.com

